

## HY series HY01002

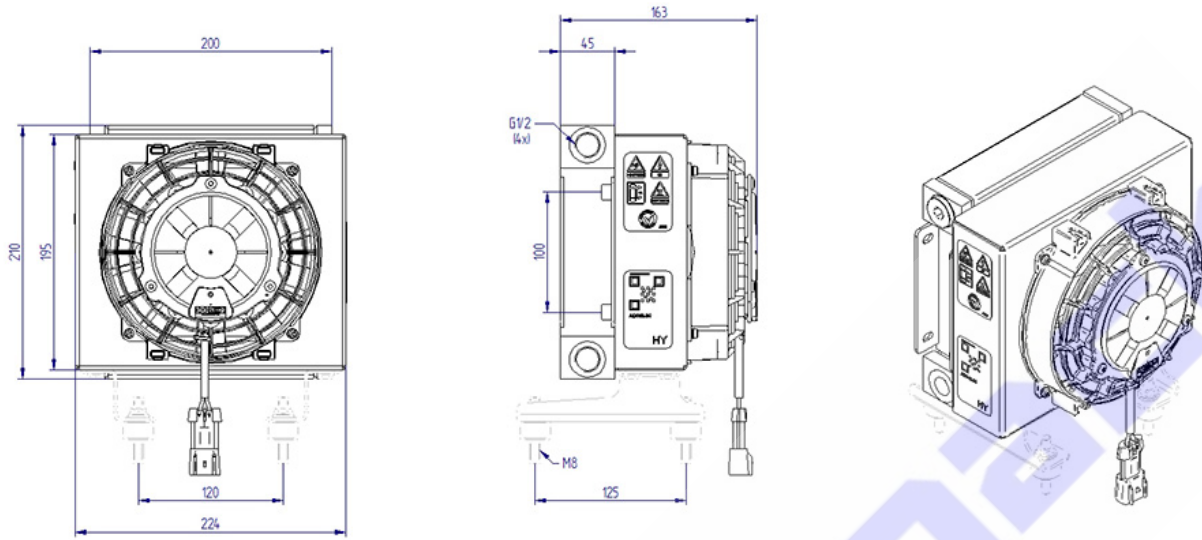

### Technical data

Item	Oil flow [l/min]	Capacity [l]	Weight [kg]	Rpm	Voltage [V]	Frequency [Hz]	Current absorption [A]	Power [W]	Ø Fan [mm]	Air flow [m <sup>3</sup> /h]	Noise level [db(A)]
<b>HY01002</b>	10-50	0.7	5		12		5.40	70	167	362	71,3
<b>HY01004</b>	10-50	0.7	5		24		2.60	70	167	362	72,8

### Performance

### Pressure drop

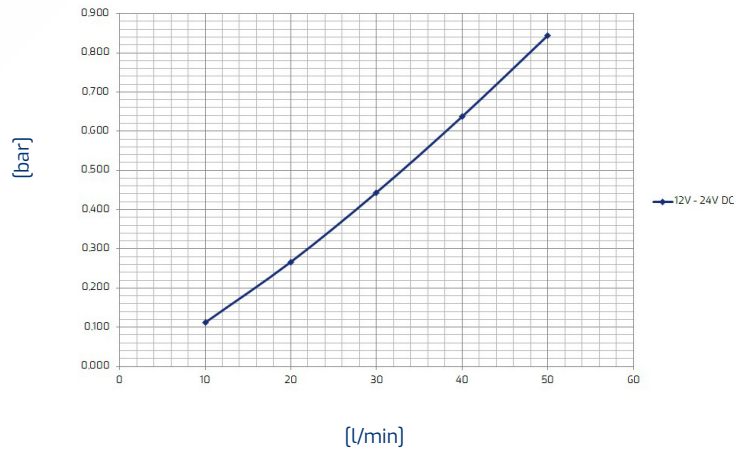
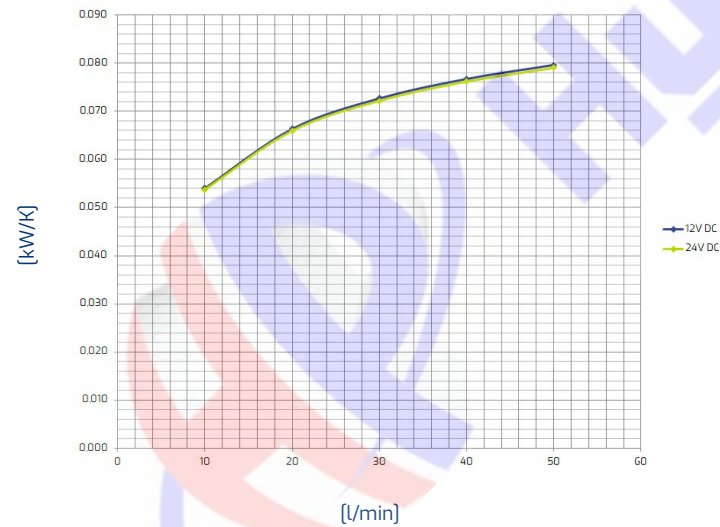

Oil T 80°C  
T Amb. 40°C

Viscosity - ISO VG 32 Oil					
Oil	22	32	46	68	150
Correction factor	0,8	1	1,2	1,6	3