

## HY series HY01802

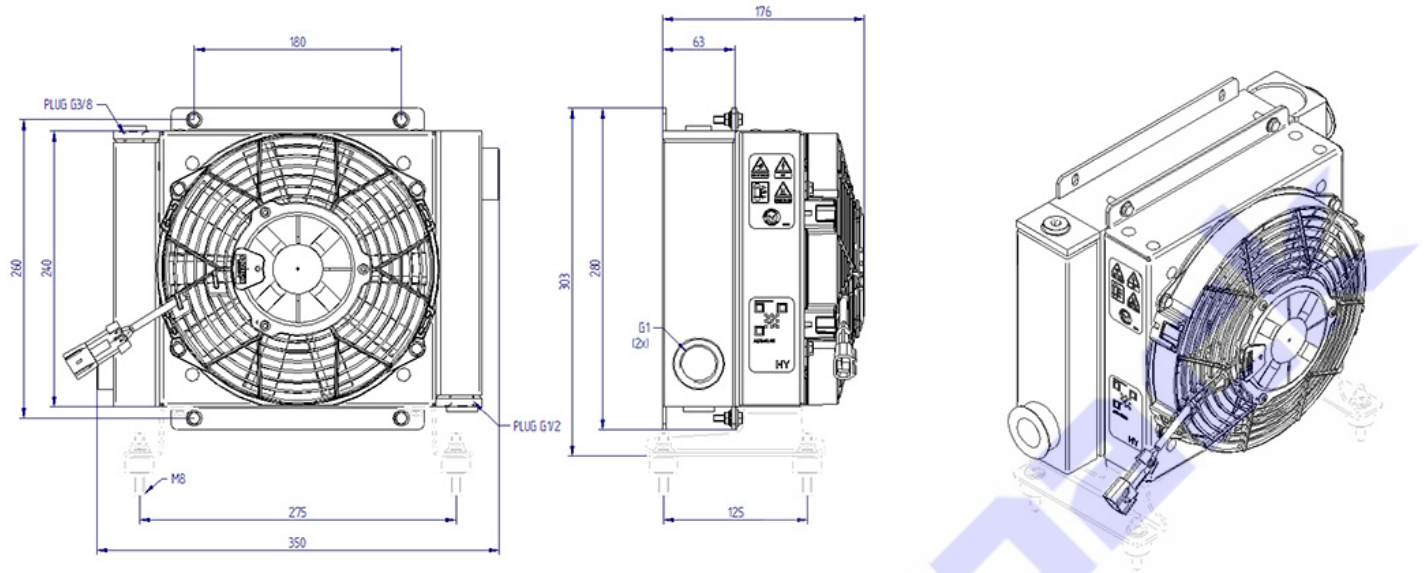

### Technical data

Item	Oil flow [l/min]	Capacity [l]	Weight [kg]	Rpm	Voltage [V]	Frequency [Hz]	Current absorption [A]	Power [W]	Ø Fan [mm]	Air flow [m³/h]	Noise level [db(A)]
<b>HY01802</b>	20-140	1,5	8		12		7,40	90	225	805	66,5
<b>HY01804</b>	20-140	1,5	8		24		3,90	94	225	805	67,3

### Performance

### Pressure drop

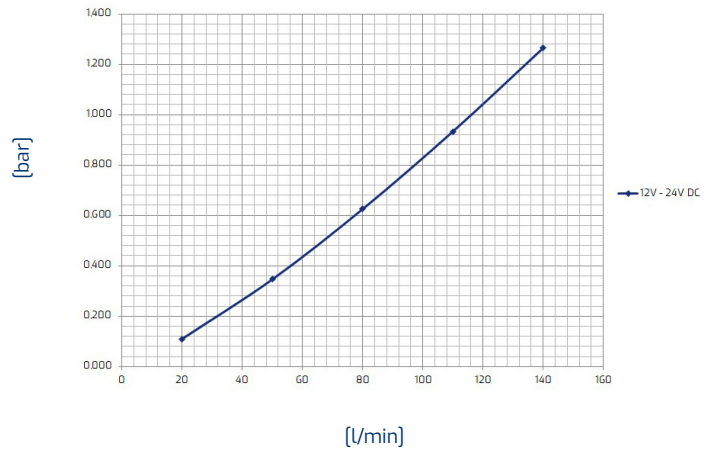
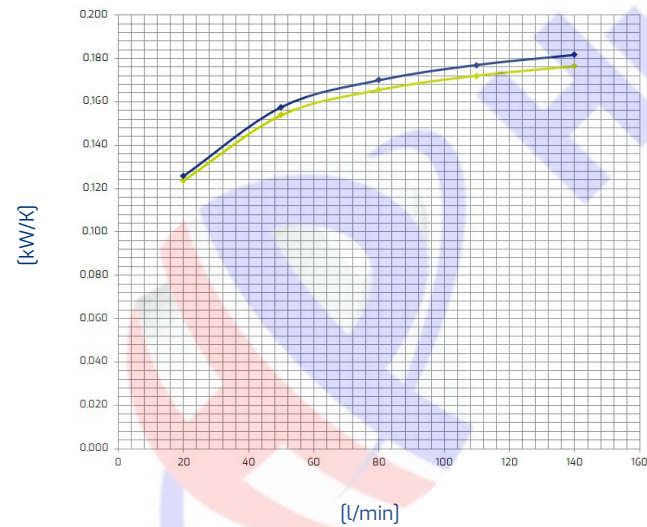

Oil T 80°C  
T Amb. 40°C

Viscosity - ISO VG 32 Oil					
Oil	22	32	46	68	150
Correction factor	0,8	1	1,2	1,6	3