

HY series

HY03802

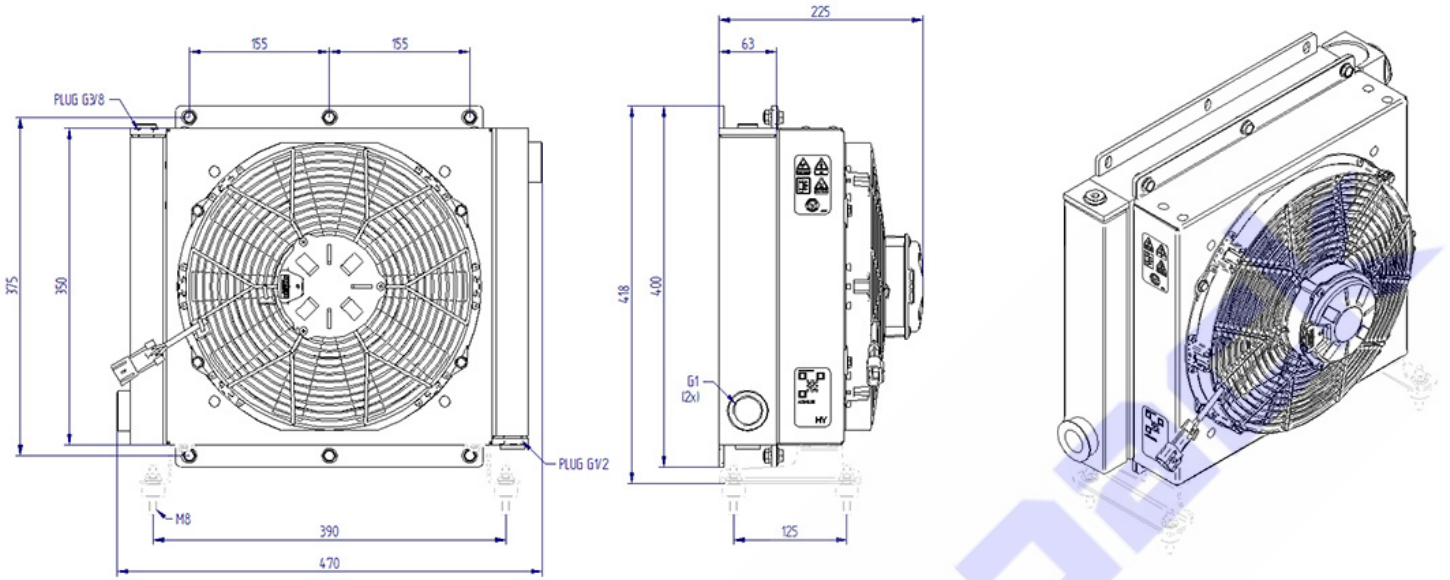

Technical data

Item	Oil flow [l/min]	Capacity [l]	Weight [kg]	Rpm	Voltage [V]	Frequency [Hz]	Current absorption [A]	Power [W]	Ø Fan [mm]	Air flow [m³/h]	Noise level [db(A)]
HY03802	20-140	2,5	14,5		12		16,40	213	305	2055	73,4
HY03804	20-140	2,5	14,5		24		8,60	223	305	2045	73,7

Performance

Pressure drop

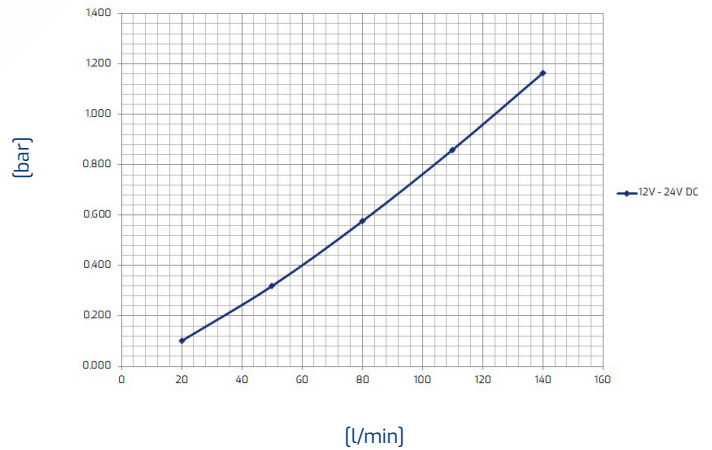
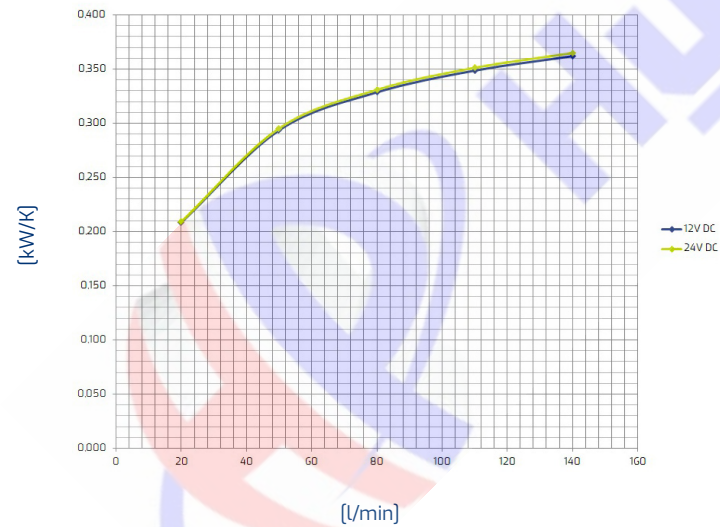

Oil T 80°C
T Amb. 40°C

Viscosity - ISO VG 32 Oil					
Oil	22	32	46	68	150
Correction factor	0,8	1	1,2	1,6	3