

## HY series HY05702

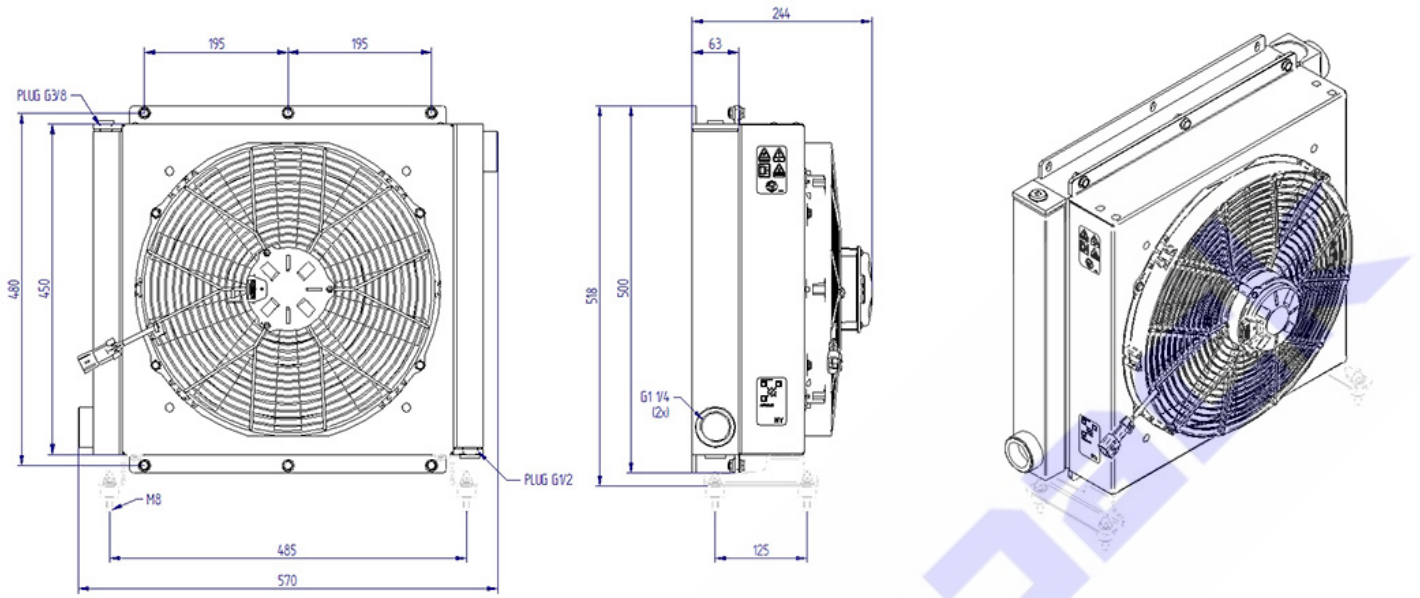

### Technical data

Item	Oil flow [l/min]	Capacity [l]	Weight [kg]	Rpm	Voltage [V]	Frequency [Hz]	Current absorption [A]	Power [W]	Ø Fan [mm]	Air flow [m³/h]	Noise level [db(A)]
<b>HY05702</b>	20-160	3,7	19		12		18,60	240	385	3260	72,4
<b>HY05704</b>	20-160	3,7	19		24		8,20	214	385	3390	72,2

### Performance

### Pressure drop

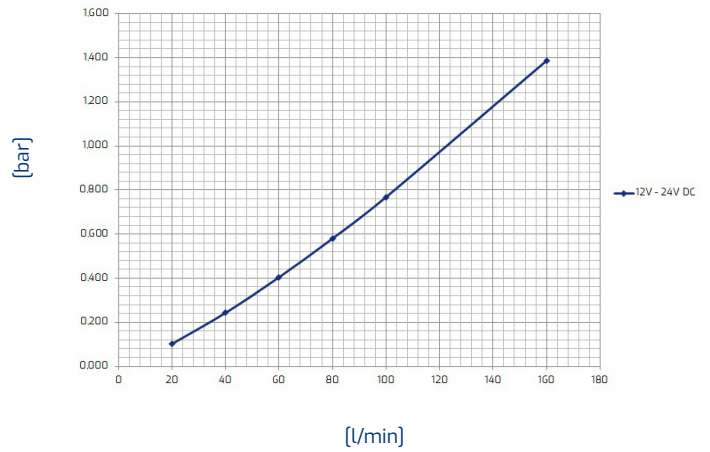
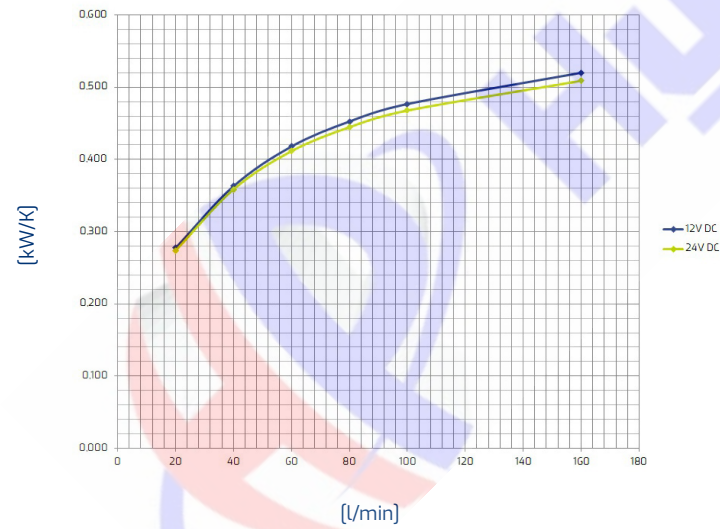

Oil T 80°C  
T Amb. 40°C

Viscosity - ISO VG 32 Oil					
Oil	22	32	46	68	150
Correction factor	0,8	1	1,2	1,6	3